

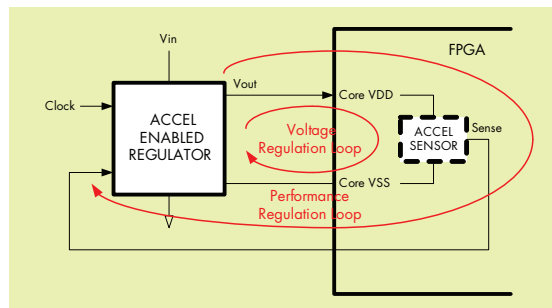

ASIC AND DESIGN SERVICES

Your Partner in Design and Manufacture

OPTIMIZE FPGA SPEED AND POWER WITH ACCEL™ TECHNOLOGY



- **Performance Regulation Transcends Voltage Regulation**
- **Higher Speed and Lower Power for Less Cost**
 - Eliminate requirement for tight supply tolerances
 - Selectable mix of speed and power benefits
- **Increase Performance without Upgrading to Higher Speed Grade**
 - Save 25-40% in device cost
- **Compatible with All FPGA Technologies**
 - Including Xilinx, Altera, and others

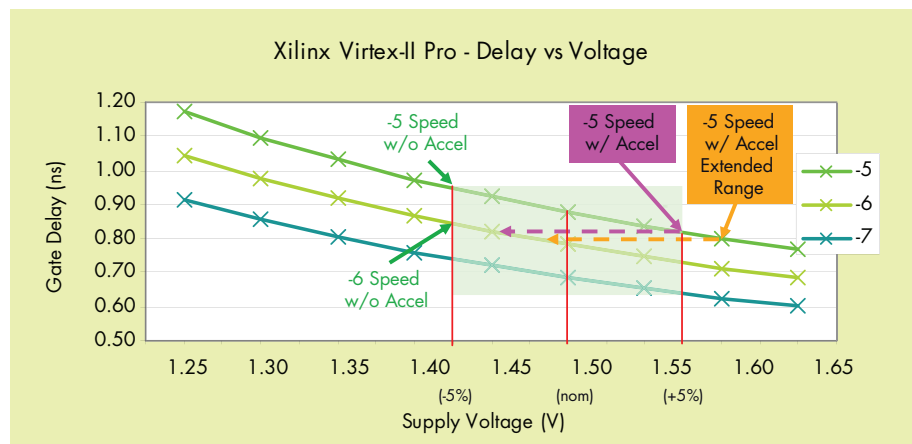



ASIC AND DESIGN SERVICES

Your Partner in Design and Manufacture

As silicon feature sizes continue to shrink, requiring lower supply voltages, tolerances in conventional supply regulation techniques have made FPGA design increasingly difficult.

Standard voltage tolerances result in a large variation in performance, making it difficult to achieve speed/power goals within a competitive development cycle. iSine has recognized the need for a more effective approach to managing performance and has developed a solution based on performance regulation to address this critical need.

For more information, contact your iSine Sales Representative.



iSine, Inc.
41 Winter Street, Suite 2
Boston, MA 02108
617.695.2700
www.iSine.com

FPGA BENEFITS OF ACCEL™ TECHNOLOGY

- **Simple and Effective Solution to Boost Performance of Existing and New Designs**
- **In-System Control of Operating Point**
 - Tune FPGA performance to design target
 - Correct timing problems without redesign
- **Increase Device Utilization**
 - Reduce buffer overhead requirements
- **Eliminate IR Drop Effects**
 - Including power distribution of die, package, and board
- **Improve Reliability**
 - Achieve speed goals with minimum power dissipation
 - Eliminate performance degradation over product lifetime
- **Accelerate Design Closure Schedule**
 - Design with tighter timing/power models
 - Compatible with standard design flows
- **Accelerate Prototype Debug Efforts**
 - Quickly flush out and correct timing problems
 - Evaluate in-system performance across voltage range

Accel™ Product Family Available for All Major FPGA Vendors and Technologies